

SPARE PARTS EXPLODED VIEW STORAGE ELECTRIC WATER HEATERS

Model

TI-SHAPE EE

R8215449-02EN - Edition 02 - 11/09/2006

877 098		TI-SHAPE 10 OR EE
877 099		TI-SHAPE 10 UR EE
877 100		TI-SHAPE 15 OR EE
877 101		TI-SHAPE 15 UR EE
877 102		TI-SHAPE 30 OR EE
Reference	Ind.	Model type	Begin	End

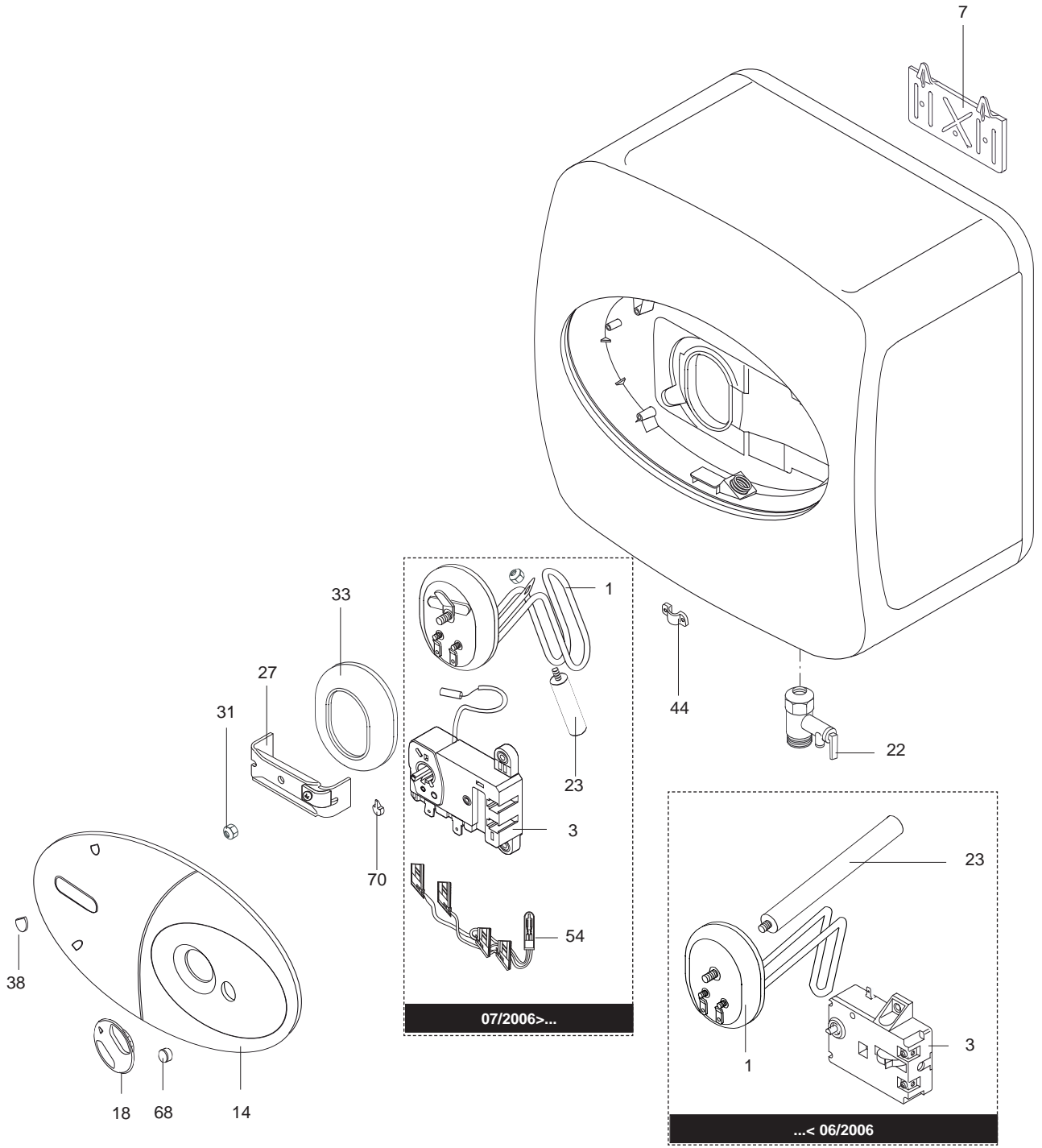

Key N	Description	Manf. Pt. N	Other	Type				Manf. date	
					10	15	30	from	to
0001	НАГРЕВАТЕЛЬНЫЙ ЭЛЕМЕНТ 1500W 220-240V	65103766			•	•	•	07/06	
	НАГРЕВАТЕЛЬНЫЙ ЭЛЕМЕНТ 1500W 220-240V	990966					•		06/06
	НАГРЕВАТЕЛЬНЫЙ ЭЛЕМЕНТ 1500W 220-240V	990967			•	•			06/06
0003	ТЕРМОСТАТ	65101079					•		06/06
	ТЕРМОСТАТ	65103771			•	•	•	07/06	
	ТЕРМОСТАТ	691499			•	•			06/06
0007	КРОНШТЕЙН	570341			•	•	•		
0014	КРЫШКА ПЛАСТИКОВАЯ	65100872			•	•	•		06/06
	КРЫШКА ПЛАСТИКОВАЯ	65103778			•	•	•	07/06	
0018	РУЧКА РЕГУЛИРОВАНИЯ	65100875			•	•	•		
0022	ПРЕДОХРАНИТЕЛЬНЫЙ КЛАПАН (1/2" 8,5 БАР)	571730			•	•	•		
0023	МАГНИЕВЫЙ АНОД D:16 L:210 M5	570241					•		06/06
	МАГНИЕВЫЙ АНОД D:13,8 L:150 M5	574305			•	•			06/06
	МАГНИЕВЫЙ АНОД D:21,3 L:110 M5	65103768					•	07/06	
	МАГНИЕВЫЙ АНОД D:21,3 L:80 M5	65103793			•	•		07/06	
0027	СКОБА ФЛАНЦА	570024			•	•	•		
0031	ГАЙКА M6	570069			•	•	•		
0033	ПРОКЛАДКА ФЛАНЦА	65100282			•	•	•		
0038	ЗАГЛУШКА	65100874			•	•	•		
0044	ЗАЖИМ ДЛЯ КАБЕЛЯ	573266			•	•	•		
0054	ИНДИКАТОРНАЯ ЛАМПА	65104037			•	•	•	07/06	
0068	КРЫШКА ИНДИКАТОРНОЙ ЛАМПЫ	573070			•	•	•		
0070	РУЧКА РЕГУЛИРОВАНИЯ ТЕРМОСТАТА	570029			•	•	•		

LIST OF THE ABBREVIATIONS

HW	: Hot water.
CW	: Cold water.
C	: Ceramic resistance (normal heating).
Ca	: Ceramic resistance (accelerated heating)
TP	: Immersion heater.
1F	: With fittings.
2F	: Without fittings.
3F	: With fittings and another outlet connection.
AMI	: With mixing valve.
SMI	: Without mixing valve.
PUISS	: Power of th appliance.
PN	: Appliance with normal pression.
LP	: Appliance with low pression.
PV	: Appliance with variable power.
PF	: Appliance with fixed power..

IDENTIFICATION PLATE

SERIAL NUMBER

Ex: 03 09 08

Manufacturing day
 Month of manufacture : from 1 to 12 → January to December
 Year of manufacture

OR

Ex: 02 11 00001 007843

Product reference
 Sequential number
 Month of manufacture : from 1 to 12 → January to December
 Year of manufacture

The indications mentioned on the prices, commercial or technical literature and the scheme are written for your guidance and are available at a given time. The CONSTRUCTOR retains the power to modify the presentation, the form, the size, the conception or the material of the products.